

CICARÉ 8R

Two seat ULM helicopter



CICARÉ 8R

TECH SPECS

Seats	2
ENGINE	
Manuf./model	Rotax 915 iS
Type	4 Cylinder boxer
Maximum power	141HP
WEIGHT	
Empty	330Kg - 730 lb
MTOW	525Kg - 1160 lb
PERFORMANCE	
Max speed VNE	194 Km/h - 100kt
Cruise speed	130 Km/h - 70kt
Vertical speed	9 m/s - 1800 ft/min
Hover ceiling	2440 m - 8000 ft
Service ceiling	3050 m - 10000 ft
Fuel type	
Mogas RON 95 E10 / AvGas UL91/UL94	
Endurance	2,5 hrs.

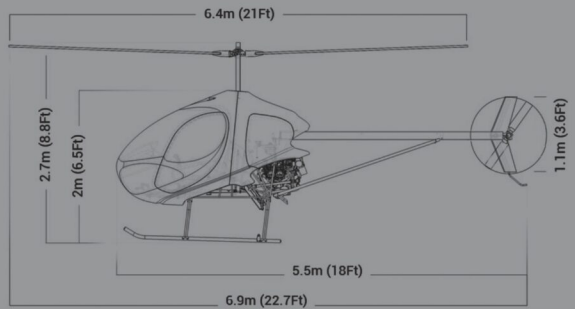

The best power-to-weight ratio in its class

CICARÉ 8R: Fuel consumption is 30% lower than certified helicopters with similar characteristics. The cutting-edge engineering and design team, with the introduction of the latest technology in materials such as carbon fiber not only achieved their goal but also, with a lower empty weight and increased payload, produced a helicopter with a stunning appearance unprecedented for this type of aircraft.



Operators: Argentina.

